

Historic, archived document

Do not assume content reflects current scientific knowledge, policies, or practices.



NOV 18 1925

UNITED STATES DEPARTMENT OF AGRICULTURE



DEPARTMENT BULLETIN No. 1350



Washington, D. C.

October, 1925

BLUE-FOX FARMING IN ALASKA

By

FRANK G. ASHBROOK, In Charge of Division of Fur Resources, and
ERNEST P. WALKER, Administrative Officer for Alaska;
Bureau of Biological Survey

CONTENTS

	Page
Introduction	1
Selecting an Island or Ranch Site	7
Ranch Organization	10
Essentials of Breeding	16
Essentials of Feeding	19
Transportation	24
Pelting	25
Characteristics of a Good Pelt	28
Losses from Depredations	29
Sanitation and Treatment of Disease	29
Failures and Abandonments	31
Breeders' Associations and Ranches	32
White-Fox Farming in Northern Alaska	32

WASHINGTON
GOVERNMENT PRINTING OFFICE
1925

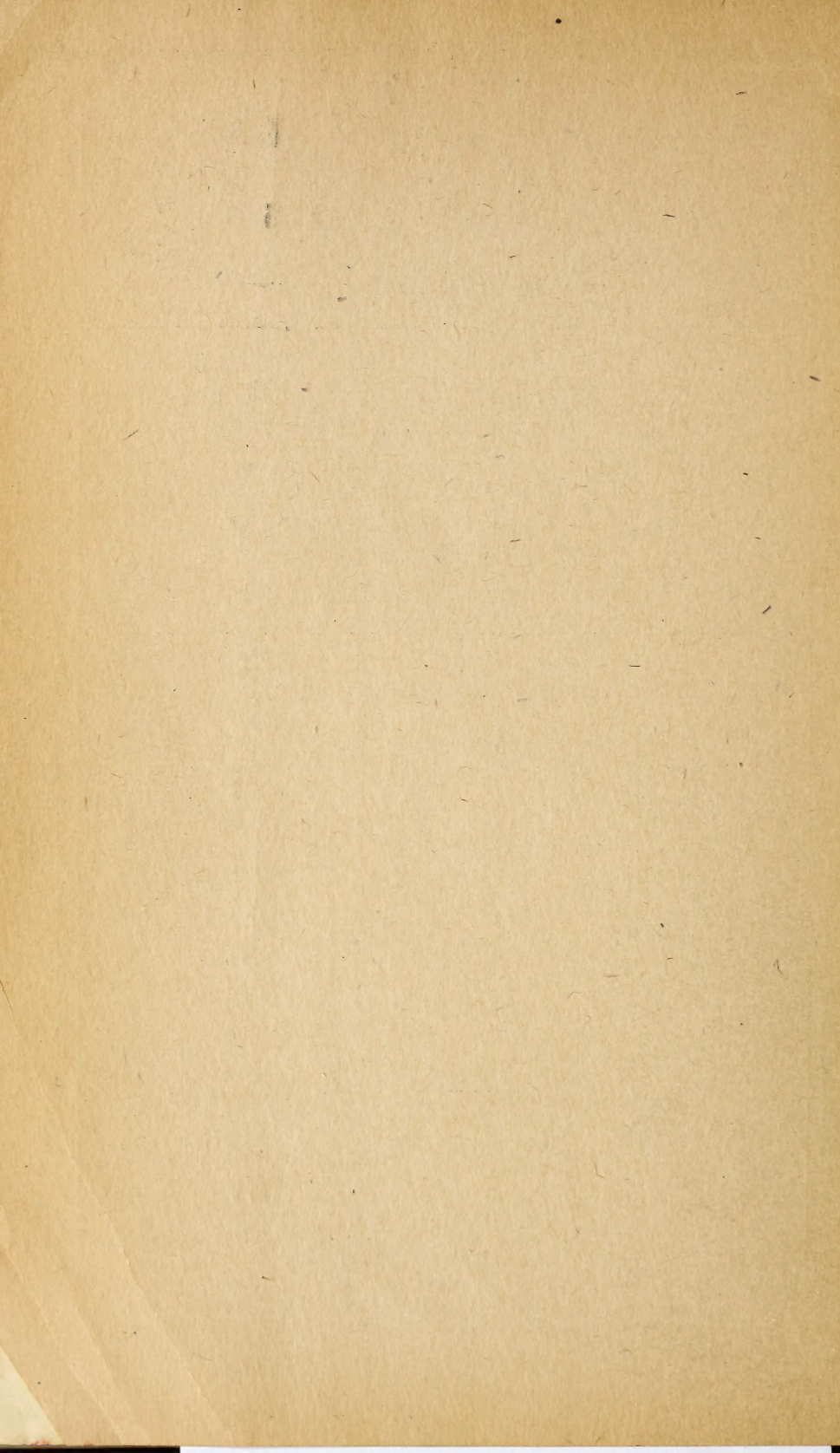

UNITED STATES DEPARTMENT OF AGRICULTURE



DEPARTMENT BULLETIN No. 1350



Washington, D. C.

October, 1925

BLUE-FOX FARMING IN ALASKA

By FRANK G. ASHBROOK, *In Charge Division of Fur Resources*; and ERNEST P. WALKER, *Administrative Officer for Alaska*; Bureau of Biological Survey¹

CONTENTS

	Page		Page
Introduction-----	1	Essentials of breeding—Continued.	
What is a blue fox?-----	3	Time of breeding-----	19
Brief history of blue-fox farming-----	4	Mating-----	19
Fox-growing areas in Alaska-----	5	Essentials of feeding-----	19
Selecting an island or ranch site-----	7	Kinds of feed-----	20
Climate and shade-----	7	Methods of preparing and feeding-----	21
Location and soil-----	8	Quantity and frequency-----	23
Harbor facilities-----	9	Transportation-----	24
Food supply-----	9	Pelting-----	25
Water-----	9	Primeness-----	25
Island area-----	10	Killing-----	26
Ranch organization-----	10	Skinning-----	26
Structures-----	10	Drying pelts-----	27
Trap-feed houses-----	12	Characteristics of a good pelt-----	28
Breeding stock and equipment-----	15	Losses from depredations-----	29
Essentials of breeding-----	16	Sanitation and treatment of disease-----	29
Pelts-----	17	Failures and abandonments-----	31
Conformation-----	18	Breeders' associations and ranches-----	32
Breeding-----	18	White-fox farming in northern Alaska-----	32

INTRODUCTION

The production of blue foxes in Alaska is a comparatively new industry, at present confined chiefly to islands along the southern coast, including the Aleutian Chain (fig. 1). It is of particular importance to Alaska, since it utilizes outlying islands that are of little or no value for agriculture.

In island blue-fox raising the foxes are allowed to roam over an entire island, where they choose their mates and make their dens. In the early days the foxes had to forage for their food, but now practically all ranchers feed them. This system has proved profitable, and, together with the increased popularity of fur for apparel, has led many persons to lease certain islands from the United States

¹The writers desire to acknowledge the help given in the preparation of this bulletin by the many fox farmers of Alaska in furnishing information of value, and the assistance in the section on diseases and parasites given by M. C. Hall, of the Bureau of Animal Industry.

Government and to claim others by squatters' rights for engaging in fur farming. So great has been the demand for islands that practically all the desirable ones under the control of the Department of Agriculture are leased for the purpose.

A number of individuals in Alaska have attempted to raise blue foxes in pens, and recent reports show that some of them have been successful (fig. 2). In addition, litters of blue foxes have been produced in captivity at the experimental fur farm of the Biological Survey, in New York State, as well as on ranches in other parts of the United States. A number of ranchers and raw-fur buyers maintain that blue-fox pelts produced in pens lack the quality and finish of those produced in the wild. This has been held to be the case with silver foxes also. Approximately 90 per cent of the silver-fox pelts sold on the raw-fur market in 1924, however, were from ranch-bred animals.

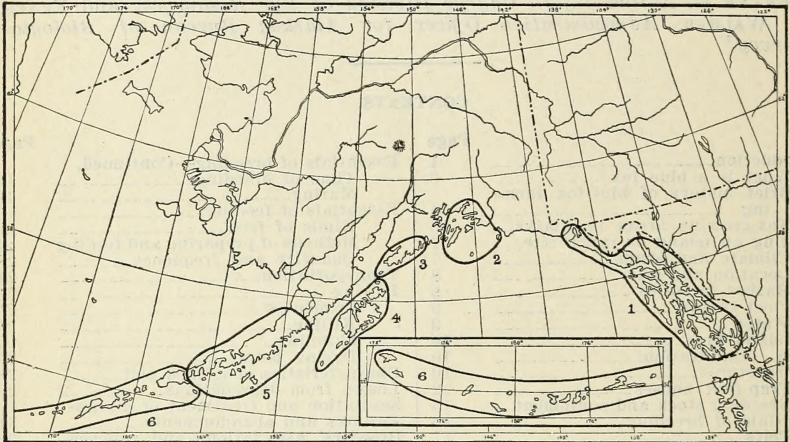

FIG. 1.—Sections of the Alaska coast where blue-fox production is becoming an important industry:

- | | |
|---------------------------------|--------------------------------------|
| 1. Southern Alaska. | 4. Kodiak-Afognak region. |
| 2. Prince William Sound region. | 5. Islands off the Alaska Peninsula. |
| 3. Lower Cook Inlet region. | 6. Aleutian Islands. |

Because the number of islands available for fox ranching is limited, those already engaged in the business should determine as quickly as possible whether blue foxes can be produced profitably in pens. If this is found possible, blue-fox ranching can spread to the mainland of Alaska, to Canada, and to the United States. With the resulting growth of the industry, there will be an increased demand for breeding stock as well as for pelts.

Blue-fox ranching is in a condition similar to silver-fox production in that it is an industry of too recent development to be supported by the results of extensive study and research. Sufficient is known, however, to assist beginners, as well as established ranchers, with information on some important phases of the business, such as organizing the ranch, breeding, feeding, pelting, and sanitation.

The information given in the following pages is based on a study of the methods and practices which have been found to give the greatest success on islands in Alaska.

WHAT IS A BLUE FOX?

A number of persons in Alaska and elsewhere mistakenly think that white foxes are found only in the Arctic, and that when they were brought to the Pribilof Islands and points farther south the climate changed the fur from white to blue.

The blue fox is a color phase of the Arctic or white fox (*Alopex*), which is circumpolar in range, being found particularly along the seacoasts of arctic and subarctic regions. Its normal winter coat is white, while the summer pelage is brown and tawny. The blue fox is dark bluish in winter and tends toward brownish in summer. There are intermediates in which the coat may be spotted blue and white, or the blue and white may be blended, producing a dingy or smoky-white appearance. Such mottled animals sometimes occur among blue foxes where there have been no white foxes. It is noted

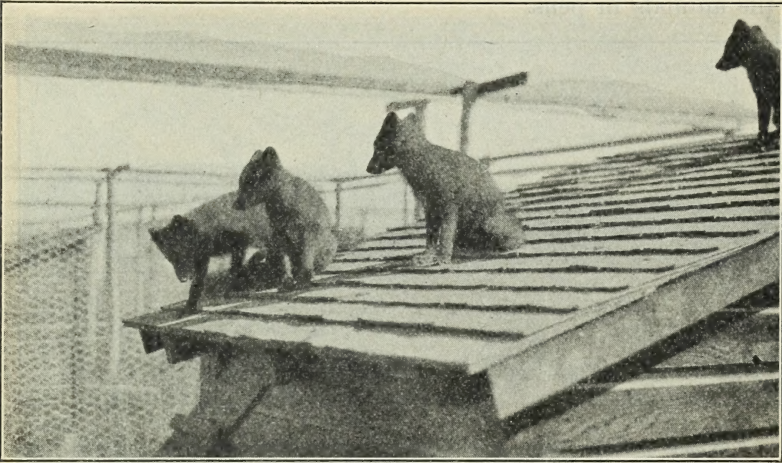

FIG. 2. Blue-fox pups sunning themselves on the roof of their den

B24761

more frequently, however, where white and blue foxes are ranched together.

The white fox is more common in the wild than the blue, and smoky-white foxes are sometimes born from blue parents; but on islands where blue foxes have been introduced and raised a pure white fox is exceedingly rare.

The prices usually paid for the different skins are governed largely by the relative scarcity of the animals and the market demand. On the raw-fur market, blue-fox skins generally bring from three to four times as much as white. At present both color phases are popular, the natural blue being preferred by the more exclusive trade; to supply the popular trade, white skins are dyed blue, steel, taupe, and rose.

In general, it may be said that prime blue-fox pelts produced in practically every section of Alaska shown on the map (fig. 1) are bringing good prices on the raw-fur markets.

BRIEF HISTORY OF BLUE-FOX FARMING

Veniaminof, a Russian writer, states that when the Pribilof Islands were discovered they were inhabited by blue and white foxes.² The larger islands of the Aleutian group also are said to have been inhabited by blue and white foxes when discovered by the Russians.³ In 1835 the Russians introduced blue foxes on Kiska Island, possibly on Amlia, and perhaps on other islands in the Aleutian Chain.

In 1858 an official Russian proclamation permitted and ordered the killing of white foxes on the Pribilofs whenever and wherever found, but there were rigid restrictions on the killing of blue foxes. The Russians followed a wise and vigorous policy of stocking lands with fur-bearing animals, giving both native and introduced forms protection with the view of maintaining a constant supply of fur. There is nothing to indicate that fur farming was carried on in a manner similar to present-day fur farming, however; that is, caring for the animals in pens.

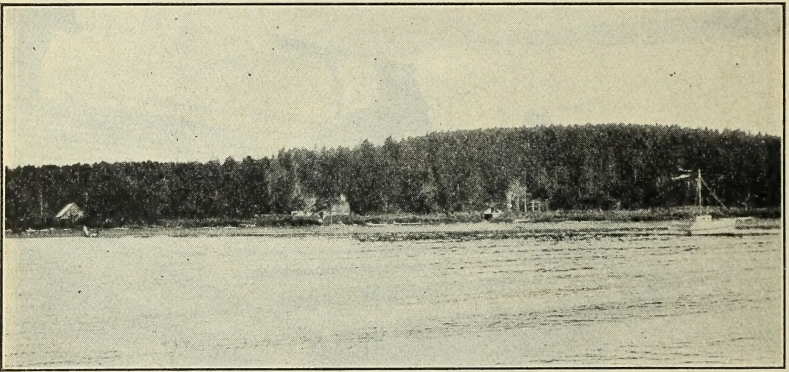

B24645

FIG. 3.—View of Long Island, near Kodiak; stocked with blue foxes. The dwelling is in the center; the buildings on the left and right are feed and storage houses, respectively

The first recorded efforts to raise blue foxes, after the purchase of Alaska by the United States, began in 1885. The Semidi Propagating Co., of Kodiak, obtained 8 or 10 pairs of blue foxes from the Pribilofs and placed them on Aghiyuk Island. This island is locally known as North Semidi, and is off the Alaska Peninsula near the present village of Chignik. About 1886 or 1887, 3 or 4 pairs were taken from the progeny on North Semidi and placed on Chowiet or South Semidi Island. A black male fox also was placed on this island, and this one killed off all the blue foxes. Chowiet was again stocked in 1891 by the Semidi Propagating Co. with 18 pairs of blue foxes from the Pribilof and Aghiyuk Islands. In 1891 this company also stocked Chirikof Island with 6 or 8 pairs from Aghiyuk and possibly some from the Pribilofs.

In 1895 the Semidi company obtained possession of Long Island, near Kodiak, from a person who had been raising cattle, sheep, and silver foxes there (fig. 3). After trapping and removing all the

² Veniaminof's Zapieska, 1840, translation by Henry W. Elliott, in "A Report upon the Condition of Affairs in Alaska" to the Secretary of the Treasury (p. 258), 1875.

³ Dall, William H., "Alaska and its Resources," pp. 498-499, 1870.

silver foxes (1895-96), they placed on the island 30 pairs of blue foxes from Aghiyuk. Whale Island was stocked in 1899 with foxes produced on Long Island.

This stocking of islands was the real beginning of blue-fox farming in Alaska. The operations of the Semidi Propagating Co. were not a complete success, but were a start in the right direction. Through its efforts stock was brought to points accessible to breeders. It is neither necessary nor desirable to go into a detailed history of subsequent developments. In fact, this soon became so intricate as to make impracticable any attempt to trace it. For a time there was a boom; then there was a decline, during which many islands were abandoned and most or all of the stock of foxes removed. Interest revived about 1916, and since then the industry has developed so rapidly that in a very few years almost all the islands suitable for the enterprise have been occupied.

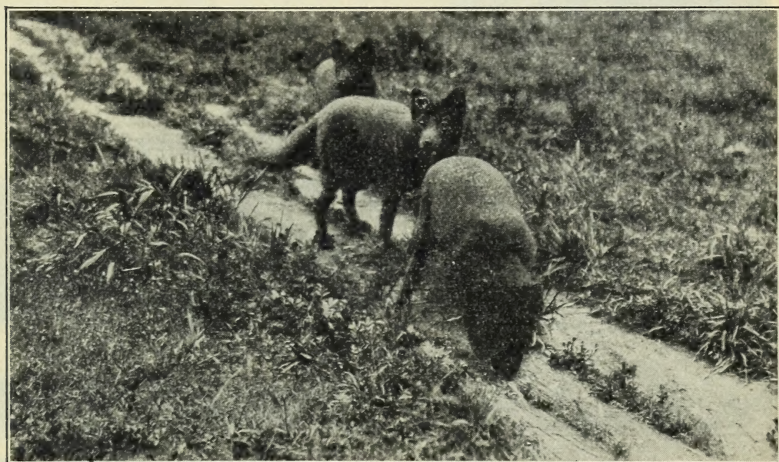

B26763

FIG. 4.—Blue foxes running wild on islands comb the beach for food. They will become very tame and even eat from the hand of their keeper

In 1898 a few pairs of blue foxes from Long Island were sent to Foxcroft, Me., and kept in pens. The animals were pups of that season and it is reported that several foxes were raised the next year.⁴ A number of blue foxes were imported into the United States from Alaska between the years 1919 and 1924. Some, at least, of the operators in the States and on the Alaska mainland have been successful in raising blue foxes in pens.

FOX-GROWING AREAS IN ALASKA

The islands used for blue-fox farming in Alaska vary in size from about 40 to more than 6,000 acres, and fall into six geographic groups (see fig. 1): (1) Southeastern Alaska (in the Alexander Archipelago); (2) Prince William Sound region; (3) Lower Cook Inlet region; (4) Kodiak-Afognak region; (5) the Alaska Peninsula; (6) the Aleutian Islands. In the first two groups the islands

⁴ Washburn, M. L., in Harriman Alaska Expedition, vol. 2, p. 360, 1901.

are almost all timbered and lie mainly within national forests. Some of the islands in the Kodiak region are timbered, but westward from Kodiak none have timber.

With respect to their availability for fur farming, these islands fall into four classes:

(1) Ten islands from Prince William Sound to the Shumagin group; namely, Little Koniuji, Simeonof, Chirikof, Long, Marmot, Pearl, Elizabeth (fig. 5), Middleton, Aghiyuk, and Chowiet. All of the islands in this group are leased and occupied for fur farming, the administration being by the Secretary of Agriculture through the Biological Survey.

(2) Islands in the Aleutian Islands Reservation are available for occupancy under permit and are administered by the Secretary of Agriculture through the Biological Survey. Applications for per-

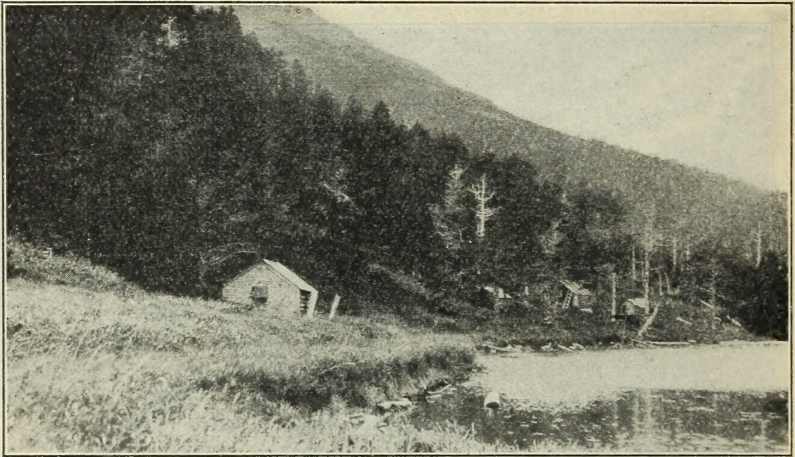

FIG. 5.—Elizabeth Island, leased for fur farming by the Biological Survey. The timber is fairly dense in the valleys. This is also true of Pearl and Marmot Islands, similarly leased

mits to occupy these islands should be sent to the office of the Biological Survey, Juneau.

(3) Islands on national forests are administered by the Secretary of Agriculture through the Forest Service, and practically all such islands suitable for fox farming are already under permit for that purpose. On the Tongass Forest, in southeastern Alaska, 150 such permits are in effect; and on the Chugach Forest in the Prince William Sound region, 36. Inquiries regarding the use of national-forest land for fox-farming purposes should be addressed to the Forest Supervisor, Cordova, Alaska, or Forest Supervisor, Ketchikan, Alaska, who are in charge of the Chugach and Tongass National Forests, respectively.

(4) Other islands, except a few small reserves, are of the public domain and under the jurisdiction of the General Land Office, Department of the Interior. No legal authority exists for leasing or granting title to these islands. A few are situated in southeastern Alaska, but the majority are west of Seward and Cook Inlet. Many

islands of this class are occupied for fur farming under the belief that those in possession will have their occupancy recognized should Congress pass the necessary law authorizing the issuance of leases or permits for them.

Shipments by mail of furs consigned to points outside of Alaska are required to be reported to the Alaska Game Commission, Juneau, Alaska, on appropriate blanks supplied for the purpose.⁵

SELECTING AN ISLAND OR RANCH SITE

CLIMATE AND SHADE

The production of a fine quality of fur is closely related to climate. A long, cold winter, with a fair amount of rainfall, particularly in spring, is conducive to the production of good pelts. Hot summers are not detrimental if short and if followed by a season of cold weather sufficiently severe to cause the renewal of heavy coats.

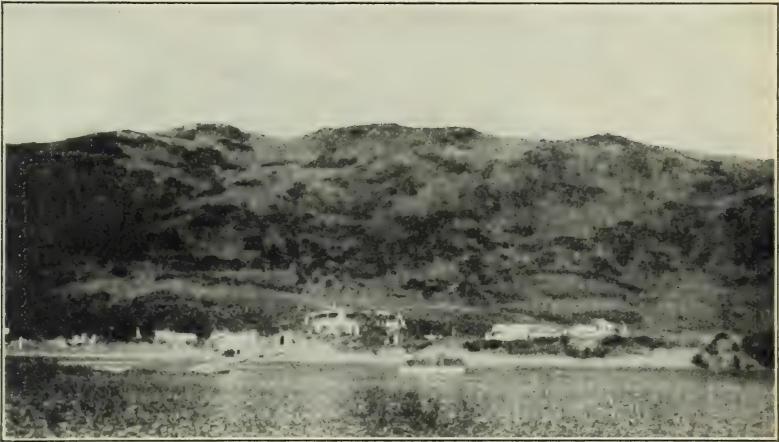

B24818

FIG. 6.—Paul Island. Scrubby underbrush is found here but no large timber

It has been stated that excessive sunshine makes the fur of live animals fade, but to what extent has not yet been definitely ascertained. The sun will make fur fade, however, after the pelt has been removed. When the fur of a blue fox is being shed the dead hairs turn to various shades of brown and chocolate. During the season when the blue-fox pelts are becoming prime, some will be found with a chocolate tinge, commonly known as rusty. This, however, is not conclusively proved to be the result of sun bleaching; in some cases it is due to inferior breeding stock, which has a tendency to produce rust color instead of a clear maltese.

A happy medium of shade and sunshine is necessary for the comfort and health of the foxes. Every animal likes to be in the shade during extremely hot weather. On the other hand, sunshine is the best natural means of keeping the ground clean and sanitary. Some of the treeless islands have scattering brush and shrubbery (figs. 6

⁵ Full text of laws and regulations relating to fur farming and the trapping of fur-bearing animals can be had on application to the Alaska Game Commission, Juneau.

and 7), and many of them have luxuriant growths of grasses and herbaceous vegetation. Others have little or no plant life, but much outcropping of bedrock. An island of the type last described is of little value for fox raising, not only because of the lack of sufficient shade but also because the denning ground is too limited.

LOCATION AND SOIL

The northward extension of island fur farms is limited by the necessity for freedom from ice bridging to adjacent lands, either by the channel freezing over or by drifting ice. It is for this reason that island farms in Alaska are restricted mainly to the southern coast line and the Aleutian Chain. The southward limit is governed by the need for sufficient cold weather to produce good fur. Near the mainland, where the winter temperatures average lower than at



B24678

FIG. 7.—General view of the top of Aghiyuk Island. There are no trees on the island and, except in hollows, very little vegetation of any kind

the outer coast, the southern limit will be farther south than in the mild outer ocean belt. The mainland area has produced good blue-fox skins as far south as Petersburg, and fur farms are being started over 100 miles farther south. It is possible that the island blue-fox zone on the Pacific coast near the mainland may extend into northern British Columbia. Along the outer coast, blue-fox farms are being established as far south as Hydaburg, on the west coast of Prince of Wales Island, although the winter climate in the section is exceedingly mild. Fur farmers on the western islands of the Aleutian Chain, which also have a mild climate, receive satisfactory prices for blue-fox skins.

Blue foxes can be successfully raised on any type of soil that is well drained and affords suitable shade and denning grounds. It has not been definitely determined whether certain types of soil are more favorable than others to fox parasites; soils possessing an undue amount of moisture, however, and densely shaded situations are favorable to their development. The elements in the soil appear to have no bearing on the quality of the fur produced.

The latitude, climate, and soil having been determined, the next important consideration is the proper location for the ranch. Fox ranches are now established on islands in every conceivable location. Some are found many miles from civilization, where transportation by regular means can not be had at reasonable intervals, where it is difficult to obtain supplies, and where the rancher is practically shut off from many opportunities for the sale of breeding stock. Energetic, progressive men will not stay long under these conditions, however, and this makes it difficult to secure the necessary labor. On the other hand, an island used for fox farming should be at least half a mile away from adjacent islands or the mainland, as the animals may escape by swimming.

HARBOR FACILITIES

It is possible to operate an island fur farm which lacks a harbor, but the disadvantages are extremely great. The value of harbor fa-



B24726

FIG. 8.—A floating dock of the type illustrated can be built easily and cheaply and is a great convenience in landing supplies and tying up a boat in the harbor

cilities can scarcely be overestimated. A harbor permits keeping a boat for use in obtaining feed, in feeding, in the transportation of skins and breeding stock, and in communicating with towns and the mainland (fig. 8).

FOOD SUPPLY

Fish is the basic article in the diet of blue foxes; hence it is essential that it be readily obtainable throughout the year. Proximity to a cannery is a great advantage, as the waste material makes excellent feed. Seals and porpoises and members of the whale family might well be more utilized than is now the case. It is essential that the food be palatable, nutritious, and inexpensive.

WATER

The presence of fresh-water springs, streams, or ponds on an island is important. During the whelping season especially it is

necessary that fresh water be supplied at or near the dens. It is almost impossible to avoid carrying water to some extent, but the problem is much simplified if the natural supply is well distributed about the island.

ISLAND AREA

The number of foxes that can be kept on a given area depends largely on the denning grounds, the number of feeding places, and the attention given. When fed at various locations on the island, foxes become accustomed to the feeding places and make their homes not far away. Even on the larger islands the dens are found in proximity to the feeding places. There is no immediate cause for concern about overcrowding. It has been estimated by the ranchers on the smaller islands—for example, those containing 40, 50, or 60 acres—that between 150 and 200 foxes can be maintained if properly fed.



B24714

FIG. 9.—Convenient arrangement of buildings for fox rancher. From left to right they are dwelling, woodshed, smokehouse, and feed-storage house

RANCH ORGANIZATION

STRUCTURES

The ranch site having been chosen, consideration should be given to the location of the dwelling house, feed-storage, cook house, smokehouse, and any other structure (figs. 9 and 10). For convenience the dwelling should be as near as possible to the harbor or landing place. In order to look after the foxes properly on large islands it may be necessary to construct one or more additional dwellings or cabins.

The feed-storage shed also should be built near the dock in order to make the haul from the boat as short as possible. This structure may be of roughly cut timbers, log-cabin style (fig. 11). For cleanliness and sanitation dressed lumber should be used when practicable. It is not essential to construct vats in which to brine-cure

or salt-pack fish. Limited quantities of fish can be salted in barrels or tierces. A cutting table or chopping block is an aid when dressing the fish as well as when cutting them into suitable sizes to feed.

Most ranchers cook cereal with the fish at certain seasons of the



FIG. 10.—Modern type of dwelling on fox island in southeastern Alaska B26772A

year, and for this purpose build a caldron or a specially designed steam cooker either in the feed house or just outside. The steam cooker, although somewhat slower than a direct-fire caldron, cooks the food more thoroughly and without burning or scorching it.



FIG. 11.—Living quarters and outbuildings constructed from native timber B24628

Steam-pressure cookers of various sizes on the market hasten cooking and simplify the process.

A smokehouse (fig. 12) for smoking fish or other feed for the foxes should be erected in the vicinity of the feed-storage house.

As dressed fish must be carried or otherwise conveyed to the smokehouse, distance is an item to be considered. The size of the house depends upon the quantity of feed required. The one shown in Figure 11 serves an island on which are 40 pairs of foxes.

Foxes should not be killed and pelted in the building where feed is stored or prepared; if necessary, a special shed should be built for the purpose. Such use of the feed house would not be sanitary and, in addition, it would favor the chances of transmission of disease.

Structures⁶ for temporary occupancy, such as are required for injured, sick, or newly purchased foxes, may be comparatively small. The style and method of construction will depend upon the location and lay of the land. A temporary pen used for the purpose may be 10 feet long, 6 feet wide, and 6 feet high. A frame of 2 by 4 material is entirely covered by No. 15-gauge wire netting of 1½-inch

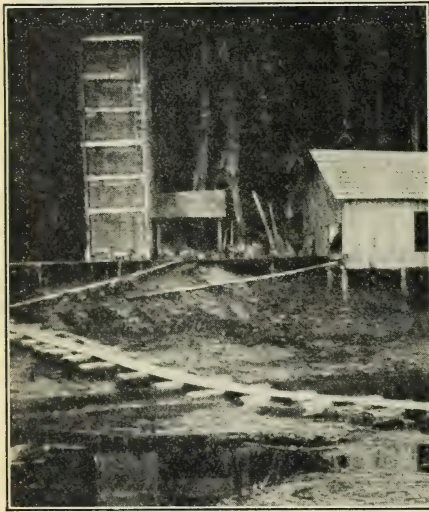

FIG. 12.—The five-tiered smokehouse illustrated will smoke and store about 5,000 salmon

mesh, with a small door in the front. As the pen rests directly on the ground, it is well to cover the floor wire with sand or fine gravel and earth. This material should be removed frequently and clean dirt substituted to prevent contamination. A small nest box should be placed inside the pen, or outside and connected with it by a chute.

TRAP-FEED HOUSES

Trap-feed houses should be erected at various points, the number and the distance apart depending on the size and topography of the island as well as on the number of foxes ranched. They provide a place where foxes may eat unmolested by eagles, ravens, and crows; and where they may be captured uninjured for marking or examination, and when prime (fig. 13). They may be built of material at hand on the island; but dressed lumber makes a neater job, and houses so constructed are much more easily cleaned. These houses should have a floor measurement of at least 6 by 8 feet and be high enough to permit a man to stand upright.

There are two types of trap-feed houses. In one the foxes enter through a trap chute and eat on the floor of the house. In the other they eat on an upper floor and fall to the ground floor when they spring the trap (fig. 14).

Figure 15 shows the first-mentioned type of trap-feed house with the trap installed. This trap, however, can be made to fit a house of almost any size or shape (fig. 16). A detailed drawing of the

⁶ Information which will be helpful to those constructing pens for raising blue foxes is contained in U. S. Dept. Agr. Bulletin No. 1151, "Silver-Fox Farming." Blue prints of plans for constructing pens and dens may also be obtained free on application to U. S. Department of Agriculture, Washington, D. C.

construction and operation of the trap itself is given in Figure 17. Foxes arrive at the entrance to the chute (1) by means of a sloped board (2). The trap floor pieces 3 and 3' are pivoted at 4 and 4', respectively. To make them reset automatically, counterweights (5

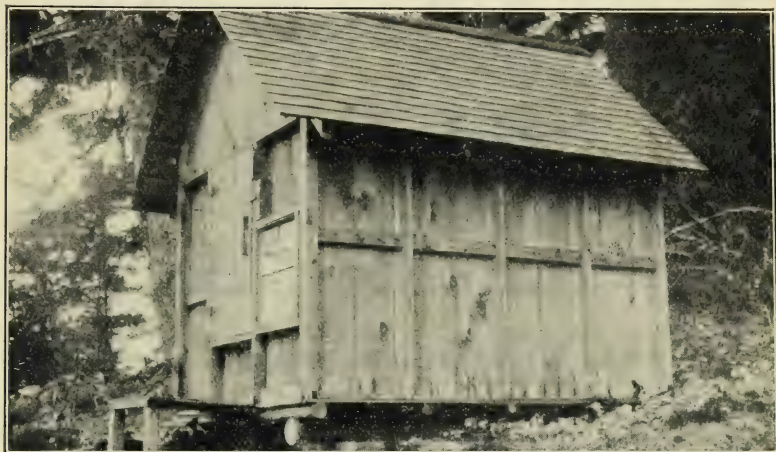

B26772

FIG. 13.—An excellent type of trap-feed house, trap for which is detailed in Figures 15 to 17

and 5') are placed on the lower side at opposite ends of the floor pieces. Floor piece 3 is securely locked and supported by the square notch (6) portion of the trigger (7). Floor piece 3' rests lightly on the beveled (8) portion of the trigger (7) so that the weight of the

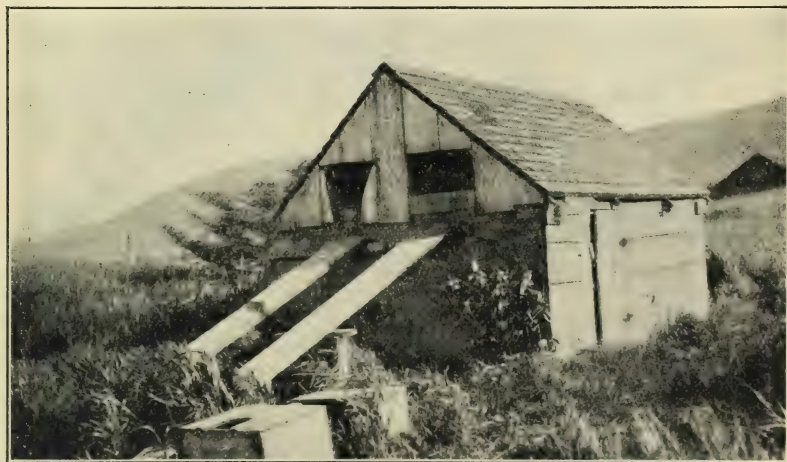

B24656

FIG. 14.—Trap house in which the foxes eat on the second floor and when the trap is sprung fall to the floor below

fox's front feet on the ends of the floor piece 3' depresses the board and forces outward the entire trigger, thus releasing the floor piece (3) from the support (6) portion of the trigger. Floor piece 3, with the weight of the hind part of the fox, and floor piece 3', with

the weight of the fore part of the animal, pivot at 4 and 4', respectively, and drop the fox to the floor of the house.

The weight of the fox removed, the counterweights (5 and 5') restore the floor pieces to position, ready for the next fox. The opening (9) of the inner end of the chute is ordinarily left open

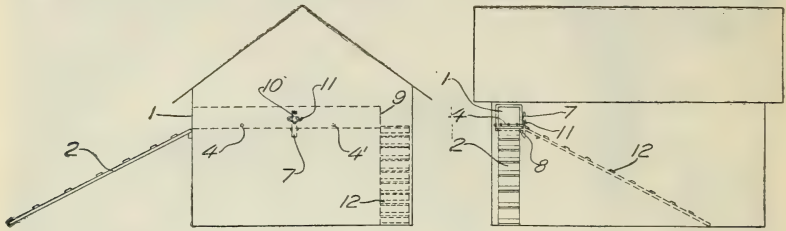

FIG. 15.—Front and side views of trap and feed house, with trap installed

in order that the animals may come and go at will, but it is closed with wire netting when the trap device is to be used. The drawings illustrate a runway board (12), similar to the board (2) previously mentioned, which is provided to permit free passage through the trap into the trap-house when desired.

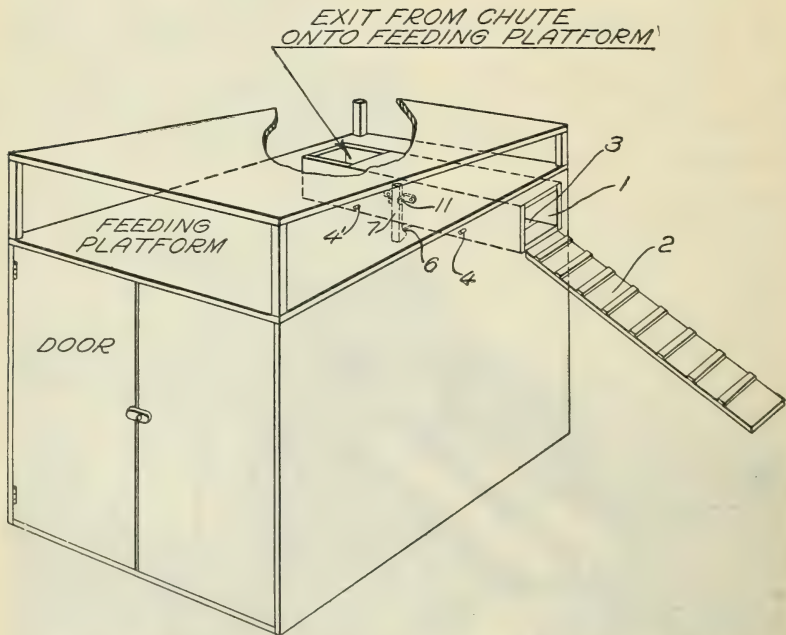

FIG. 16.—Trap and feed box that can be installed in a house of almost any description

A light spring (10), pushing outward above the pivot of the trigger, insures the trigger returning to place. When the trap is not in use the trigger should be removed and a cleat nailed across the free ends of the trap floor boards of the chute, thus making the floor solid. The trigger (7) should be made of hardwood, or

the notch (6) and the bevel (8) faced with metal. All moving parts should fit accurately and work freely.

The entrance (2) and exit (12) may be interchanged to meet conditions of installation. Where this is done, however, the positions of the beveled notch (8) and the square notch (6) on the trigger (7) will have to be reversed.

Some ranchers make use of a box-trap similar to that shown in Figure 18. This type of trap is simple to construct, but is not very satisfactory for general use. It is sometimes used to capture foxes that have become too wary to be caught in trap-feed houses. In the front part is built a sliding door, temporarily held up by a nail in a slot. A wire fastened to this nail extends to the rear of the trap through a series of screw eyes, which serve to keep it straight. On the end of the wire the bait is fastened. When a fox enters the trap and gnaws at the bait the nail slips from the slot and drops the door. A treadle or pan is sometimes used instead of bait. To re-

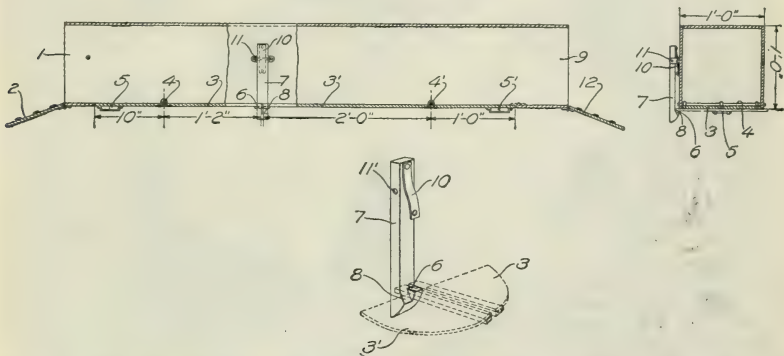

FIG. 17.—Details of construction of trap for feeding house. Operation described in text

move the foxes, the lid (which is the board propping up the trap in fig. 18) is taken off.

BREEDING STOCK AND EQUIPMENT

The number of foxes to be purchased to stock an island depends very largely upon the financial ability of the person engaging in the industry and upon the size of the island. Some island ranches of 100 or more acres have been started with only 1 or 2 pairs of breeders; but this is impractical, for the reason that much time is involved in waiting for a sufficient increase to permit the taking of pelts or the selling of breeding stock. A 50 to 100 acre island may ordinarily be stocked with 10 to 20 pairs of foxes. Good breeding stock can usually be purchased for \$300 to \$400 a pair.

A moderate-sized dwelling of logs or frame construction for the caretaker and his family can be built for \$500 to \$2,000, depending largely on the cost of labor. Large islands sometimes require more than one dwelling to provide proper distribution of caretakers. A combined feed, storage, and cook house, frame construction, will cost \$300 to \$500. Smokehouses cost \$500 to \$700, depending upon the plan. Trap-feed houses, which should be erected at numerous points

about the island, cost \$15 to \$25 each, depending upon the quality of lumber used and the labor. Feed cookers can be constructed or purchased at a cost of \$15 to \$50. Detention pens are necessary to confine foxes during short periods for various purposes, and can be built for \$25 to \$50.

A good, substantial boat is needed to procure fish for feed, to feed the foxes, and to transport supplies to and from the mainland or other points. The location of the island, harbor facilities, and the quantity of supplies to be transported will help determine the kind of boat to be purchased. A motor boat used for short, light hauls

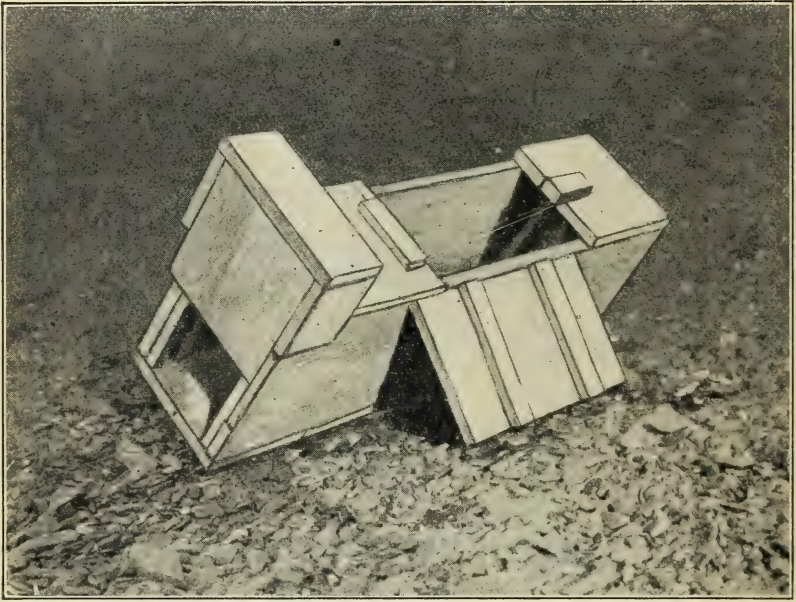

B24651

FIG. 18.—A box trap used on some island fox ranches. The fox, feeding on the bait at the rear, pulls a wire which drops the entrance door. (Top removed and used to prop trap on side for showing interior wire)

can be purchased for \$600 to \$1,000. A boat used for traversing long distances will cost \$2,000 to \$4,000.

ESSENTIALS OF BREEDING

Success in fox raising is directly dependent upon a careful and intelligent selection of the right type of breeding stock. Those engaged in the industry should have a clear conception of the important factors involved in breeding. When the animals are confined in pens and the ancestry is known, selective breeding is a comparatively simple matter. When the foxes run wild and breed promiscuously, however, as is the case on the islands of Alaska, it is impracticable to follow any definite system. In other words, the rancher is never quite sure that certain young foxes are the offspring of any particular pair of adults. Some ranchers, of course, may feel reasonably certain of the ancestry of one, two, or even three lit-

ters on an island, but this is generally a very small part of the breeding operations.

The real basis for selecting breeding foxes is the quality of fur produced. Indications from conformation occupy a secondary place.

PELTS

At the time the foxes are trapped to pelt, the rancher should carefully select and retain desirable animals for breeding stock. The pelt should be perfectly and evenly furred all over, both on the back and on the belly. A fur that is reasonably long, lustrous, and silky indicates that the animal is in good physical condition. The underfur should be abundant, soft, and dark in color, the darker the better. Matted or woolly underfur is not desirable. (See fig. 19.)

When prime, a blue fox should be a dark maltese color throughout the entire pelt. Clearness of color is one of the most important



FIG. 19.—Blue-fox pelts ready for inspection by raw-fur buyers

B2493M

factors in determining quality. Deficiency in luster and a rust or tinge, which gives a brownish or chocolate cast to the fur, reduce the value. A breeding fox possessing a rusty pelt, no matter to what degree, should be eliminated. A perfectly furred pelt, slightly tinged, is less valuable on the fur market than one fairly well furred but clear in color. Rust or tinge has been attributed to many causes, including breeding, feeding, and sunlight. It is possible that heredity is a determining factor and that the undesirable characteristic can be eliminated by careful selection.

The term "samson" is applied to foxes devoid of guard hairs and having a very inferior woolly fur. This condition has been variously attributed to feeding, breeding, and parasites. The real cause is not definitely known, and for this reason it is highly inadvisable to use such foxes for breeding. The pelts have small value on the market.

The brush should be reasonably long, in order to balance properly with the length of the body. The general principles determining the quality of fur on other parts of the body are equally applicable to the brush.

CONFORMATION

Conformation involves the individual structure of each part as a unit. A defect in any part offsets to some extent an otherwise perfect structure. Some parts, as the chest, back, loin, or leg, are relatively of greater importance than the others; a deficiency in such parts would have more effect on the serviceability of the whole than a similar inferiority elsewhere.

Constitutional vigor is evidenced by a well-developed heart girth, chest, front flank, and loin, and both vixen and dog should be deep, wide, and well coupled in these regions. There should be no indication of a pinched appearance behind the shoulders or in the loin. If breeding foxes are strong in these regions it is safe to assume that, other things being equal, they have strong lungs and heart, and consequently are stronger, healthier, and more able to resist disease.

BREEDING

It is to be constantly borne in mind that blue foxes are not domesticated animals in any sense of the term. The purpose of breeding blue foxes is to produce good fur and to improve the stock. The business of blue-fox ranching is comparatively new, and he who would succeed in it must give it careful thought, study the moods of the animals, and prepare himself to meet intelligently emergencies as they arise. Many companies formed for the sole purpose of raising foxes have failed because of the great difficulty in hiring a keeper having the necessary personal interest in the welfare of the animals. The more thoroughly a man studies breeding practices and his foxes, the more closely he may approach a uniform degree of success in his breeding operations.

The only method of breed improvement that the blue-fox rancher can use, unless he is raising the animals in pens, is grading and close culling of inferior stock. On islands where steel traps are used instead of trap-feed houses, all animals trapped are killed. In this way the best may be killed and the poorest left for breeding stock. By use of trap-feed houses, however, the poorest animals can be killed and the best liberated for breeders. On islands formerly producing pelts having a high percentage of white hairs, this condition has now largely been eliminated by following this system, and the stock is darker and clearer colored.

Grading is the mating of a common or relatively unimproved animal with one that is more highly improved. In the case of domestic animals the male is selected as the improved one of the pair for reasons of economy. In the blue-fox business, however, it is well for the improvement to be made both ways. Improvement by grading is, of course, limited to the foxes on a particular island. This method distributes breed excellence rapidly and with certainty; that is, the unimproved blood soon becomes insignificant and finally disappears. Only those individuals meeting standard requirements should be retained for breeding.

Of the effective means at the command of the breeder to improve the stock, next in importance to selection is the judicious mating of related animals. This process is known as inbreeding. Inbreeding can be carried on successfully only where animals are kept in confinement and their identity known. Following the method of grading just described, however, and not introducing new and better males from other sources, would eventually result in inbreeding.

TIME OF BREEDING

Most blue-fox pups mate at the age of 10 months and produce young when they are about a year old. Apparently the breeding season varies slightly in different regions and at times is influenced by variation in the climate. The mating season, or, as it is commonly known among ranchers, the "barking" period, starts about the first of February and continues for approximately 40 days. Most of the matings occur during February and March.

So far as known, the oestrus, or heat period, occurs once a year and lasts 3 or 4 days. While the vixen will accept service only at this time, it seems to make little difference whether it is early or late in the period.

The gestation period is 51 or 52 days and the young are usually whelped in April or May, although sometimes as late as the middle of June. Litters vary in number from 1 to 14, but the average number raised is about 5.

MATING

Improving the stock by selective breeding will undoubtedly result in increased profits in fox raising. If the more remote as well as the immediate ancestors have been bred with the aim of producing extra fine pelts, then the chances are that this will be transmitted to most of the offspring from such matings.

In selecting blue foxes for breeders, it is to be borne in mind that pelts have a tendency to become lighter with age. No foxes showing white markings in the fur should be kept for breeding. Occasionally, however, a blue fox may show a white star on its breast, but this is not objectionable.

The possibilities of modification or improvement by selective breeding are fully as great with foxes as with domesticated animals, and selective breeding will therefore in time produce a much finer strain of foxes.

Ordinarily blue foxes have only one mate, but occasionally a male will have two, and there are a few reports of a male having three.

ESSENTIALS OF FEEDING

The real object to be kept in mind in feeding foxes is to supply nutritive material for building and repairing the body and for producing good fur. The ration must be wholesome and acceptable, and at the same time reasonably cheap. Cleanliness in preparation and regularity in feeding are important.

While it is recognized that it is almost impossible to follow out ideal systems of feeding under present conditions on islands, yet it

would be well to adopt as nearly as possible the methods here outlined.

For the best results, a palatable feed must be provided. The same combinations should be used steadily, and sudden changes either in the diet or in the manner of feeding should be avoided. It is not meant that the same kinds of feed should be given during every season of the year; but the danger is pointed out that foxes may be "thrown off their feed" by such radical changes as occur when a rancher suddenly adopts a new ration on learning of another's success with it.

KINDS OF FEED

As fish is readily obtainable in this region and forms part of the natural diet of blue foxes, it constitutes in one form or another the



B2462M

FIG. 20.—Dall porpoises are used to some extent as a fox feed. (Photograph by J. L. Hill)

major part of the feed. Salmon, cod, halibut, rockfish, skates, and herring are all used. The kind most commonly fed, however, is salmon, because of its comparative abundance during the summer and of the fact that many ranchers are able to obtain heads and discarded fish from local canneries. In localities where hair seals, porpoises, and white whales can be procured, these also are used. (Fig. 20.) Occasionally larger whales drift or are towed ashore, and foxes have been fed on them.

Mushes also form part of the diet, and are made of a variety of ingredients. Cereals, such as rice, oatmeal, bran, shorts, middlings, bread, and cracker waste, are used, and in some cases seal, whale, and porpoise oil. Ranchers who can raise root crops have added potatoes and turnips. These vegetables are never fed raw. Where obtainable, cracklings resulting from the rendering of lard in packing houses are used extensively.

A ration composed of a variety of feeds gives better results than a very simple fare, even though the latter supplies the proper proportion of proteins, carbohydrates, fats, and minerals.

METHODS OF PREPARING AND FEEDING

The preparation of the feed and the method of feeding have a great influence on the breeding of foxes and the production of fine pelts. Only clean and wholesome food should be supplied—never putrid or diseased material. A few extra dollars spent to obtain the right kind may save many hundreds later, for a proper diet and satisfactory methods of feeding are important factors in lessening the chances of outbreaks of disease.

Fish are generally obtained by the rancher fresh from the water; or, if the ranch is near a cannery, cull fish and refuse may be procured. (Fig. 21.) Fish may be fed fresh, salted, smoked, or dried.



FIG. 21.—Cull fish and fish refuse from canneries are used for fox feed B24650

Formerly most ranchers prepared their fish for winter by salting, but more recently many have adopted the method of smoking and drying a large portion. The process of smoking is practically the same as that followed with fish intended for human consumption; that is, each one is split, cleaned, and hung in a smokehouse until lightly smoked. If the smokehouse is of sufficient capacity, the fish may remain there until needed. This enables the rancher to supply a little heat occasionally to prevent mildewing. Where climatic conditions permit, fish are dried in the sun without smoking and then stored in a dry place until needed for winter feeding. (Fig. 22.)

In salting, the fish are split and cleaned and each piece rubbed lightly with salt and packed tightly in barrels or tanks, or the cleaned pieces may be placed in layers and the salt sprinkled over them. The same method is followed with fish heads.

Some ranchers report satisfactory results in packing both fish and whale meat in fish, whale, or seal oil. Their experiments were made

for the purpose of determining the value of the oil as a preservative and whether or not it is palatable to the foxes.

Dried and smoked fish has the advantage over other feeds that it can be fed without any further preparation and does not freeze in winter. Some ranchers, however, cook it in mushes. It is essential that all salt fish be soaked in running water for a period of five days to a week before being used. (Fig. 23.) It can then be given to the foxes without further preparation, or be cooked in mushes.

All mushes fed to foxes are prepared along one general line. The chief ingredient is generally fish in one form or another. This is boiled for a time, and then there is added rice, finely ground wheat, or rolled oats. All of these cereals may be used, but one is sufficient. Chopped vegetables, such as potatoes, turnips, or mangels, may be added and the whole boiled until the cereals and vegetables are



FIG. 22.—Fish being dried in the sun for storing for winter use

824658

thoroughly cooked. Whale, seal, or fish oil is sometimes added and thoroughly mixed in. This forms a reasonably thick mush. The relative proportions of the various ingredients are roughly as follows:

	Per cent
Fish.....	40
Cereals.....	25
Vegetables.....	25
Oil.....	10

Feed can be cooked in large kettles over an open fireplace or in the double-boiler manner. Although it cooks more quickly in kettles, there is danger of burning it. The use of a double boiler, though slower, prevents this. To simplify the process some silver-fox ranchers use a steam-pressure cooker. Where this is practicable, it would be entirely satisfactory for the blue-fox rancher also.

A number of kinds of fox biscuits can be purchased, but analyses have shown that the majority are deficient in the needed mineral

material. Biscuits prepared according to the following recipe have been used successfully and are relished by young as well as old foxes:

Biscuits.—To a mixture of ground whole wheat, middlings, and cracker waste weighing 70 pounds, add 1 pound of baking powder and 30 pounds of cracklings or fish meal. Mix with enough water to form a stiff dough. Place in pans approximately 10 by 12 inches in size and 1½ inches deep, and bake in a slow oven 1½ to 2 hours.

When thoroughly baked these biscuits are not dry and hard, but are more like cake. They are not fed fresh, but are allowed to stand for a day or two.

All feed should be given in dishes, preferably of aluminum or earthenware. Under no circumstances should it be thrown on the ground, as such practice makes it impossible to keep the surroundings clean and sanitary and the feed itself from becoming contaminated.



B24640

FIG. 23.—A basket arrangement like that illustrated is built in a stream to freshen salt fish

Fresh clean water should be accessible to the foxes at all times, whether supplied by streams on the island or placed in dishes.

QUANTITY AND FREQUENCY OF FEEDING

The quantity of feed supplied depends entirely on the season of the year and the age, appetite, and condition of the stock. Foxes should be fed fairly heavily just before the breeding season, so they will be in good, vigorous condition. Some ranchers believe that heavy feeding at this time will bring on the oestrus quicker and increase the chances of conception. Forced feeding has a tendency to make the fur prime sooner than it would be naturally, but the advisability of practicing this is questionable, because in many cases the fur thus becomes prime before the skin.

Appetite is a good index to feeding, and the quantity of feed supplied should be regulated so that the foxes will remain active and show an eagerness to eat.

In the early days of island fox farming few, if any, of the ranchers fed their animals, and the foxes were compelled to forage for their food, living on rodents, birds, and such material as they could find on the beach. While such practices resulted in small litters and high mortality, a number of ranchers still follow them, but the more successful are giving considerable attention to methods and time of feeding. There is still room for improvement, however, for although some ranchers feed every day, others feed only every other day or only twice a week. Those who feed at long intervals place the feed at widely separated points on the island, while those who feed more frequently usually have more evenly distributed feeding places. Feeding in quantity at widely separated points results in the animals' colonizing in the vicinity of these places.

Wherever possible the foxes should be fed once a day. The feed, no matter of what kind, should never be thrown on the ground or on the floor of the trap house, but should always be placed in dishes.

During the whelping season, fish—either fresh, dried, salted, or smoked—should be cut into convenient sizes so that the adult foxes can carry it to the dens for the young. It is very important that plenty of feed be supplied at this time to insure that the pups shall receive sufficient nourishment. In every case where it is at all practicable to do so, it will well repay the rancher to carry feed and water to dens where young are known to be. Five-gallon oil cans with the tops cut out and wooden handles fitted in, or galvanized buckets are used for carrying feed to the foxes.

Difficulty is often experienced at the pelting season in inducing the foxes to go into the trap house. This can be avoided if a practice is made of feeding the animals in these houses regularly at all seasons. It has the further advantage of furnishing old as well as young foxes a sheltered place in which to eat, thus protecting both the feed and the animals from eagles.

TRANSPORTATION

Foxes in good condition can be shipped almost any distance; but if the journey is long, as is generally the case in Alaska, or the shipment large, it is well to have an attendant go along to feed and care for the animals. Foxes can go without feed for two or three days with no apparent ill effects. In transit they have a tendency to lose their appetites, and should be fed carefully, although fresh water should always be supplied. Small pieces of meat, preferably liver or beef, and fox biscuit may be given.

It is not advisable to place more than one fox in a compartment of a shipping crate. A crate 2 feet high containing two compartments and having a total floor space of approximately 2 by 3½ feet is large enough to carry a pair of foxes. It should be made of wood, and wire of 1-inch mesh should be nailed inside to prevent the foxes from chewing the wood. In the front of each compartment dishes for feed and water should be fastened where they can be filled from the outside. A good substantial crate, such as is detailed in Figure 24, receives better treatment in transit than a poor one.

PELTING

The business of fox raising is based on pelt value, and the most successful fox ranchers market some pelts every year. This, of course, can not be done on islands where the business has just started. In such cases it will be necessary to wait two or three years for the stock to increase.

It is not good practice to pelt pups, as their skins lack finish both in the fur and in the leather. Occasionally a pup skin of exceptional development sells for a good price, but this is not the rule. It is better for the rancher to carry the young over until they are at least a year and a half old and the pelt has developed into a more market-

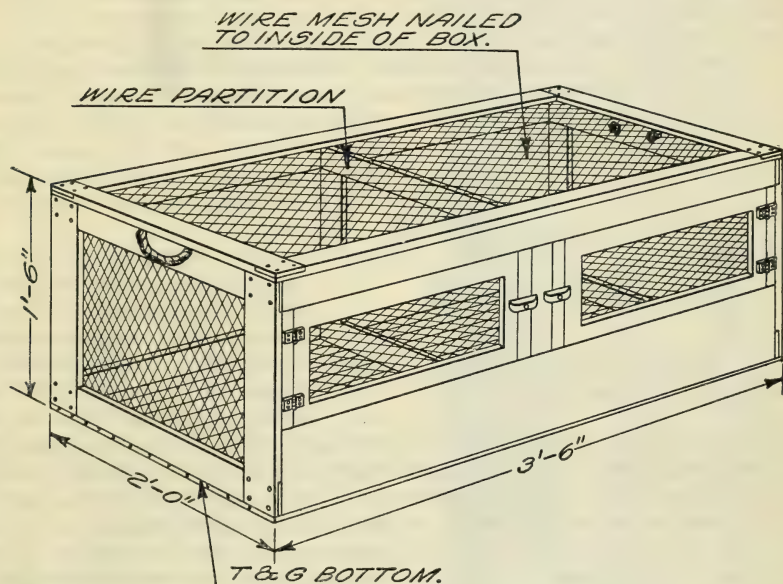

FIG. 24.—Shipping crate for two foxes, made of $\frac{3}{8}$ -inch material, tongue-and-groove bottom, and 1-inch mesh, 14-gauge wire netting

able skin. Foxes not desirable for breeders, however, should be pelted at the first opportunity.

When animals are caught for examination and pelting, those not killed should be marked in order to show that they have been trapped and then released for breeding. Males can be marked by clipping a ring of fur around the tail near the body. Females can be marked in the same manner, the ring clipped being near the tip of the tail. Records should be kept of animals pelted and of those released for breeding. Wherever practicable more females should be left than males.

PRIMENESS

Pelts of foxes usually become prime in November or December, depending upon the weather, climate, and feeding. Primeness is the highest perfection of quality in a pelt. When the pelt shows

high quality and finish, determined by its texture and sheen, it is said to be prime.

Ability to judge primeness comes only through experience. When the fur is coming prime it does so rapidly, and after it reaches the peak of perfection it soon becomes overprime, losing its sheen and finish. When foxes are running wild this point can not be watched so closely as when they are raised in pens.

KILLING

In killing, the method generally pursued is for the caretaker to catch the fox with the tongs (fig. 25), lay it on its side, and then press his foot on its chest. Striking the fox on the back of the head with a club leaves a blood clot on the pelt and sometimes cuts it. A more humane and satisfactory method of killing is by the injection of a solution of strychnine sulfate. Objection has been made to this on the supposition that strychnine may injure the pelt by causing the hair to fall out. This, however, is not the case. The effect,

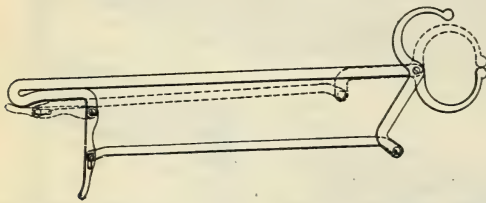

FIG. 25.—Diagram showing operation of fox tongs. Tongs are useful in handling animals after they are captured in the trap house

if any, of strychnine on the hair follicles is contracting rather than relaxing.

The operation of injecting strychnine is very simple. The instrument used is a small hypodermic barrel syringe with a reasonably long needle, and a quantity of a 3 per cent

solution of strychnine sulfate. The syringe is filled with the solution and the gauge set for 1 cubic centimeter. The fox is placed on its right side and held by an attendant. The operator places his hand on the chest to locate the heart, at the same time feeling for a space between the ribs to avoid running the needle into the bone. The needle is inserted in the direction of the heart and the dose discharged. In less than a minute the fox dies without a struggle. Great care should be exercised in using strychnine as it is a deadly poison.

SKINNING

After the animal heat leaves the body the flesh shrinks from the skin, thus permitting the pelt to be removed more easily and keeping the skin side free from blood. Cooling will take place in about half an hour, but during this interval care should be taken to prevent the carcass from freezing.

The only tool needed in skinning a fox is a jackknife, and this should be kept sharp during the operation. A slit is made up the back of each hind leg, starting at the inside of the paw and running to the hock, then from the hock to a point just below the root of the tail. The back of each front leg is slit in the same manner from the paw to the first joint. The skin of the hind legs is then worked free from the flesh from the first joint to the claws, and the bones of the claws are cut free from the pelt, but the nails are allowed to remain with the skin. A slit on the under side is made

from the root of the tail about half its length and all of the tail bone is pulled out of the brush.

The carcass is then hung on a hook or nail by the tendons of the hock joints and the pelt is pulled down, the knife being used whenever necessary to free it, until it is removed as far as the neck. Careful work is necessary to cut around the base of the ears, including them in the pelt, then around the eyes, and around the mouth and lips in such way as not to injure their margins. Carcasses should be disposed of immediately by burying or burning.

DRYING PELTS

As soon as it is taken from the carcass the pelt is placed flesh side out on a wooden frame for drying. This may be made of softwood one-half to five-eighths of an inch thick. Soft material will facilitate drying and the drawing of tacks. A board 45 inches long and approximately 7 inches wide should be used, tapering at the end so as to enter the nose. At a distance of 12 inches from the nose the board should be 6 inches wide, and at the base 7 inches. Cut the board in halves, lengthwise, and on the sides of one of the pieces fasten two cleats extending at right angles at the base, so that when the frame is inserted into a pelt and a wedge is forced in to stretch it tight there will be no overlapping of the boards (fig. 26). By varying the size of the wedge any frame may be used for both large and small pelts. No more stretching should be done than is required to bring the skin into natural shape, for undue stretching detracts from the value of the pelt. To allow the skin to dry, the hind legs and tail are fastened to the frame by means of tacks and small strips of wood, and the front legs are tacked to small pieces of wood, as illustrated in Figure 27.

A tablespoon is used as a scraper to flesh the skin and remove any excess fat. Scraping should not be so close as to remove all the fat and part of the membrane, for this will make the skin shrink from the roots of the guard hairs, permitting them to be pulled out, thus limiting the life of the pelt. Fur buyers look for this defect, and skins having it are severely cut in price.

After the skin has been fleshed and dried on the frame for a day or so, depending on conditions, it should be taken off, turned fur



FIG. 26.—Frame for drying pelts. B21648 Instead of having a middle wedge, some frames are made in one piece and serve the purpose equally well

side out, and immediately replaced. After another day or two it should be again removed and hung on a rope to finish drying. The drying usually takes about four or five days, and should not be hurried by use of artificial heat as this has a tendency to injure it.

After the skin is thoroughly dry it is shaken vigorously and worked with the hand to make it pliable. It is then brushed with a stiff brush and rubbed with burlap to remove all foreign material. A comb may be used, if necessary, to remove dead hairs. All cleaning is done by hand, and no chemicals should be applied.

Frequent handling and brushing at this time does not injure the pelt, but rather puts it in better condition for the raw-fur market.

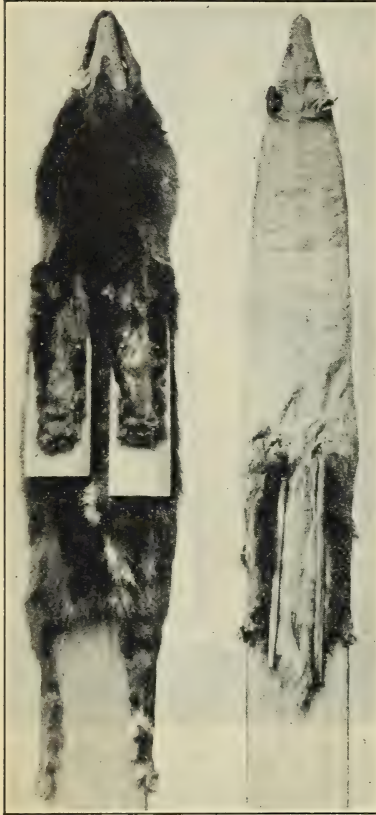

FIG. 27.—Pelts on drying frames, illustrating method of thoroughly drying legs and brush

CHARACTERISTICS OF A GOOD PELT

Primeness.—In general, in judging a blue-fox pelt the main thing to be kept in mind is quality, and this is affected by many factors. First, the pelt must be prime. This is determined by examining the skin side, which, if the pelt is fresh, should be fairly white or cream-colored and show some “life” when handled. This side turns yellow with age and loses its firmness. The skin should be perfectly and evenly furred, both on the back and on the belly, with the fur reasonably long, lustrous, and silky. Guard hairs should be evenly and thickly distributed, as the silky texture and luster are largely dependent upon them. The brush should be sufficiently long to maintain a balance with the rest of the pelt. There should be no rubbed spots or defects.

Clearness of color is an important factor in determining the quality of a pelt. There should be no tinge or rust to give the character-

istic chocolate or brownish cast. Careful fur buyers make a greater cut in the price of a pelt having a rust or tinge than for any other defect. As a rule, more is paid for a clear, bright-colored pelt not so well furred than for a well-furred skin with a brownish or faded appearance.

Size is the last consideration in valuing a pelt. A difference of 3, 4, or 5 inches does not reduce the value of a skin, provided it passes other requirements. An extra large pelt is not desirable, for the principal reason that it is not becoming to the average wearer.

LOSSES FROM DEPREDATIONS

Some losses among foxes are caused by predatory birds and mammals. Eagles are widely charged with catching young foxes, and there are authentic records of their doing so. The fur farmer is well warranted in making war upon them in the vicinity of the fox ranch. Wolves have been reported as killing foxes, but it is believed that instances are rare.

The extent of losses from poaching is not known. Marking animals and skins with registered brands, as required by Territorial law, reduces the likelihood of handling stolen skins. The drastic laws and substantial penalties now imposed are reducing losses from poaching.

SANITATION AND TREATMENT OF DISEASE⁷

The diseases of the blue fox in Alaska are few, and the distances between islands lessen the danger of transmission of diseases and parasites. In maintaining the health of foxes, preventive measures against disease must be chiefly relied upon. With the blue fox the prevention of disease is far easier than its treatment.

Sanitation.—Places frequented by foxes should be kept reasonably clean, particularly in the vicinity of the dens and feeding grounds. This is very difficult, especially where foxes are at liberty to roam an entire island; but in spite of this, some attempts to clean up should be made.

Close attention should be given to the methods of feeding. Nothing but clean, wholesome feed should be given. Animals that have died should not be fed to foxes unless the meat can be made safe by thorough cooking. No moldy feed should ever be used, as it causes diarrhea and sometimes death. Foxes can not be prevented from carrying food into their dens, but this habit can be lessened by feeding them at regular intervals and by giving only as much as will be consumed with relish. Food left at the dens or the feed houses for any length of time will mold or otherwise spoil. All dishes used should be clean and the water supplied should be pure and fresh.

When blue foxes are first purchased they should be carefully examined for any abnormal conditions. Even though apparently in good health, they should be placed in pens and kept under quarantine and close observation two to four weeks before being turned loose. Sick animals should be captured and isolated at once to prevent the spread of disease; and if disease breaks out on an island or on a ranch, a strict quarantine should be maintained.

Dead foxes should never be permitted to lie around, but should be burned or buried. If it is desirable to examine a dead body, cut open the chest and abdomen the entire length. Examine the stomach and intestines for worms. If pneumonia was the cause of death, the lungs will be a dull red and will sink when placed in water.

⁷ This section was prepared by D. E. Buckingham, a veterinarian sent to Alaska by the Biological Survey during the summer of 1924 to investigate blue-fox farms, particularly on islands, with special attention to the matter of sanitation and disease.

Treatment of disease.—Taking measures looking toward sanitation and the prevention of disease are functions of the fox farmer. Treating disease, however, calls for a veterinarian, and the diagnosis of disease and the administration of drugs are the province of experts. A fox farmer's general knowledge of diseases and the application of remedies is naturally limited. Blue foxes are difficult to treat, and in administering remedies it is necessary to employ strategy. Mature foxes usually can not be treated successfully except by catching and then restraining them with either wooden or metal tongs, such as are advertised extensively in fur-farming magazines (see fig. 25). Sometimes the fox can be induced to eat tasteless medicine placed in food.

When fox pups start to look for food they sometimes eat to excess, and the resulting indigestion is indicated by cramps or colic. A fox showing such symptoms should be captured and given 1 or 2 teaspoonfuls of castor oil. If the animal is cold or has been wet it should be kept warm and confined in a box; if it is bloated or swollen, Epsom salt should be administered, one-half teaspoonful in 2 tablespoonfuls of hot water. No food should be given but hot milk or hot beef tea. Rough handling should be avoided, and time enough should be allowed for the frightened puppy properly to swallow liquids. A fatal pneumonia is apt to be caused by pouring more liquid into the mouth than can be swallowed.

Foot disease is a pus infection. It is first localized in the sweat glands between the toes and then spreads into the lymph channels and the blood-stream, causing a lymphangitis with extreme swelling of the foot. A number of cases have developed into gangrene of the foot bones as well as multiple abscesses along the back and tail. One case revealed on post mortem an acute abscess of the dorsal gland of the tail, with other clinical symptoms of pyemia. The so-called foot disease may be communicable, but the general indications are that it is not. The causes of foot disease are not definitely known, but extreme moisture, insanitary dens and surroundings, or faulty feeding may be causative factors. Affected parts of blue foxes having foot disease are being examined by specialists of the Bureau of Animal Industry, and the findings will be made known as soon as definite information is obtained.

Wounds.—The lameness sometimes noted in young foxes found on the shore is generally due to wounds from stepping on sea urchins, one of their favorite foods. The spines of sea urchins are very sharp and sometimes will penetrate the sole of a shoe.

Slight wounds of the skin from bites and lacerations from other foxes readily heal because of the dust-free air and licking by the animals, but large wounds should be treated. If the wound has hanging flaps, cut them off. Remove all hair, grit, and pus from the sore, and then flush it with peroxide of hydrogen. After the wound has been properly cleansed, apply boric acid 4 parts and alum 1 part.

Cannibalism.—Cannibalism among foxes is not normal. Some authorities believe that it is purely a mental disorder, though it may be further increased by the taste of blood. There seems also to be an instinct among wild animals to kill sick mates. The vixen's desire to destroy her young may result from any of a number of

causes. If constipated, she becomes feverish and develops an abnormal appetite, and in this condition may eat her pups. To prevent this, laxative feeds, as cod-liver oil, eggs, liver, linseed-oil meal, and biscuits, should be fed during pregnancy. Undue excitement or injury during this period may also influence the destruction of young. Some ranchers have advocated the feeding of salt pork and salt fish to eliminate this tendency, but this remedy is not always successful. Extraction of canine teeth is a mechanical way of stopping widespread injuries and losses from cannibalism.

First-aid remedies.—The following remedies should be kept on all fox farms in about the quantities mentioned:

Alum (dried), 4 ounces.

For light bleeding. Added to boracic acid, 1 part in 4, it makes a non-poisonous dusting or wound powder.

Boracic (boric) acid, 1 pound.

Nonpoisonous and used freely as a dusting powder on open wounds. Dissolved in hot water it is valuable for bathing inflamed parts.

Epsom salt, 1 pound.

For use as a laxative, 1 teaspoonful in half a glass of warm water.

Flaxseed, 1 pound.

For warm, antiseptic poultices for boils, abscesses, and swollen feet. Boil in water until it assumes the consistency of a thick mush and apply while warm and moist.

Iodine (tincture), 4 ounces.

Used in full strength just as for human cuts and wounds.

Lysol (1 to 2 per cent), 8 ounces.

Disinfectant and antiseptic. Follow directions on bottle.

Peroxide of hydrogen, 1 pound.

Follow instructions on bottle and the directions in this bulletin.

Sulfur (powdered), 1 pound.

Use in ointment made with 1 part sulfur and 4 parts lard, or other pure fatty base, for skin diseases and bald spots.

FAILURES AND ABANDONMENTS

In the course of the development of the blue-fox industry, there have been a number of failures and abandonments of undertakings. Almost every one of these can be attributed to neglect of important factors of one kind or another. Some ranchers have attempted to raise foxes by placing a few animals on an island and then going away for long periods and leaving them to take care of themselves; others have left negligent or incompetent caretakers in charge; and still others, starting without sufficient capital to carry them to a producing state, have been compelled to neglect or even to abandon the industry. Failures under such conditions are not surprising, for successful fur farming requires the same attention and energy that is necessary to success in any other business.

BREEDERS' ASSOCIATIONS AND RANCHES

Blue-fox raising in Alaska has increased rapidly in the past few years. At present (1925) there are four breeders' associations representing the industry in the Territory, as follows:

The Southeastern Alaska Blue Fox Farmers Association, at Juneau.
 The Blue Fox Farmers Association of South Central Alaska, at Cordova.
 Cook Inlet Silver and Blue Fox Breeders Association, at Seldovia.
 Southwestern Alaska Blue Fox and Fur Farmers Association, at Kodiak.

According to the most recent reports to the Biological Survey, there are 232 ranches in the Territory, distributed as follows: In



B2753M

FIG. 28.—White foxes in pens at Shishmaref, on the Seward Peninsula. Overhead wire is necessary to prevent the foxes from escaping over snowdrifts

southeastern Alaska, 129; in the Prince William Sound region, 36; in the Lower Cook Inlet region, 14; in the Kodiak-Afognak region, 14; in the islands off the Alaska Peninsula, 13; and in the Aleutian Islands region, 26.

WHITE-FOX FARMING IN NORTHERN ALASKA

Several experiments have been undertaken by individuals in northern Alaska in raising white foxes for their fur. The white fox is the normal phase of the Arctic fox *Alopex*, as noted on page 3 of this bulletin, and the description of the white and blue phases and their relationships are there mentioned. The experiments already undertaken have indicated the possibility that white-fox farming will be-

come an important part of the fox-farming industry, not only of Alaska, but wherever the animals are found in the pure white, or normal, phase.

The increasing demand for fox furs is evidenced by the growth of the fox-farming industry, and that white foxes will play an important part in its future is indicated by the fact that of 92 permits issued in 1925 by the department for the capture of Alaskan fur bearers for propagating purposes, 33 were for taking white foxes. Persons engaged in the production of white foxes in the northern parts of Alaska are optimistic regarding the future of the industry and predict that it will some day equal or even surpass other industries which to-day are of much greater importance in the Territory.

The habitat of the Arctic or white fox is limited chiefly to the north polar regions, but extends south as far as Labrador. In the wild the white fox is more common than its relative in the blue phase.

Although the white fox is one of the smaller foxes existing, its pelt is one of the most popular. The estimated annual production of white-fox pelts in 1925 was as follows: North America, 30,000; Asia, 25,000; and Europe, 10,000. The prices paid for pelts are controlled largely by the relative scarcity of the animals and the market demand. Blue-fox pelts generally sell for much more than those of white foxes. Owing to the difference in the price of the skins many white pelts are dyed to imitate the natural blue. White-fox pelts are dyed various other shades also to harmonize with present-day colors in dress.

Like silver foxes, white foxes are confined in pens (fig. 28) and a number of ranches for them have been established on the Seward Peninsula. This section of Alaska is well adapted to fox ranching because of the abundance of cheap food, as herring, humpbacked salmon, seal meat, and reindeer offal, which white foxes take readily. The production of these animals in captivity has not been carried on long enough, however, to give definite advice regarding their feeding, breeding, and handling. The information found in this bulletin and in Department Bulletin 1151, "Silver-fox Farming," will be found helpful to pioneers in white-fox raising.

PUBLICATIONS OF THE UNITED STATES DEPARTMENT OF AGRICULTURE RELATING TO FUR ANIMALS

FOR FREE DISTRIBUTION BY THE DEPARTMENT

- Economic Value of North American Skunks. (Farmers' Bulletin 587.)
The Muskrat as a Fur Bearer. (Farmers' Bulletin 869.)
Rabbit Raising. (Farmers' Bulletin 1090.)
American Moles as Agricultural Pests and as Fur Producers. (Farmers' Bulletin 1247.)
Game Laws for the Season 1925-26. (Farmers' Bulletin 1466.)
Laws Relating to Fur Animals for the Season 1925-26. (Farmers' Bulletin 1469.)
Beaver Habits, Beaver Control, and Possibilities in Beaver Farming. (Department Bulletin 1078.)
Reindeer in Alaska. (Department Bulletin 1089.)
Silver-fox Farming. (Department Bulletin 1151.)
Blue-fox Farming in Alaska. (Department Bulletin 1350.)
Trapping on the Farm. (Yearbook Separate 823.)
Directory of Officials and Organizations Concerned with the Protection of Birds and Game, 1925. (Department Circular 360.)

FOR SALE BY THE SUPERINTENDENT OF DOCUMENTS, GOVERNMENT PRINTING OFFICE, WASHINGTON, D. C.

- Deer Farming in the United States. (Farmers' Bulletin 330.) Price, 5 cents.

ORGANIZATION OF THE UNITED STATES DEPARTMENT OF AGRICULTURE

September 24, 1925

<i>Secretary of Agriculture</i> -----	W. M. JARDINE.
<i>Assistant Secretary</i> -----	R. W. DUNLAP.
<i>Director of Scientific Work</i> -----	_____
<i>Director of Regulatory Work</i> -----	WALTER G. CAMPBELL.
<i>Director of Extension Work</i> -----	C. W. WARBURTON.
<i>Director of Information</i> -----	NELSON ANTRIM CRAWFORD.
<i>Director of Personnel and Business Administration</i> -----	W. W. STOCKBERGER.
<i>Solicitor</i> -----	R. W. WILLIAMS.
<i>Weather Bureau</i> -----	CHARLES F. MARVIN, <i>Chief</i> .
<i>Bureau of Agricultural Economics</i> -----	THOMAS P. COOPER, <i>Chief</i> .
<i>Bureau of Animal Industry</i> -----	JOHN R. MOHLER, <i>Chief</i> .
<i>Bureau of Plant Industry</i> -----	WILLIAM A. TAYLOR, <i>Chief</i> .
<i>Forest Service</i> -----	W. B. GREELEY, <i>Chief</i> .
<i>Bureau of Chemistry</i> -----	C. A. BROWNE, <i>Chief</i> .
<i>Bureau of Soils</i> -----	MILTON WHITNEY, <i>Chief</i> .
<i>Bureau of Entomology</i> -----	L. O. HOWARD, <i>Chief</i> .
<i>Bureau of Biological Survey</i> -----	E. W. NELSON, <i>Chief</i> .
<i>Bureau of Public Roads</i> -----	THOMAS H. MACDONALD, <i>Chief</i> .
<i>Bureau of Home Economics</i> -----	LOUISE STANLEY, <i>Chief</i> .
<i>Bureau of Dairying</i> -----	C. W. LARSON, <i>Chief</i> .
<i>Fixed Nitrogen Research Laboratory</i> -----	F. G. COTTRELL, <i>Director</i> .
<i>Office of Experiment Stations</i> -----	E. W. ALLEN, <i>Chief</i> .
<i>Office of Cooperative Extension Work</i> -----	C. B. SMITH, <i>Chief</i> .
<i>Library</i> -----	CLARIBEL R. BARNETT, <i>Librarian</i> .
<i>Federal Horticultural Board</i> -----	C. L. MARLATT, <i>Chairman</i> .
<i>Insecticide and Fungicide Board</i> -----	J. K. HAYWOOD, <i>Chairman</i> .
<i>Packers and Stockyards Administration</i> -----	JOHN T. CAINE, <i>in Charge</i> .
<i>Grain Futures Administration</i> -----	J. W. T. DUVEL, <i>in Charge</i> .

This bulletin is a contribution from

<i>Bureau of Biological Survey</i> -----	E. W. NELSON, <i>Chief</i> .
<i>Division of Fur Resources</i> -----	F. G. ASHBROOK, <i>in Charge</i> .
<i>Division of Alaska Investigations</i> -----	E. W. NELSON and W. F. BANCROFT, <i>in Charge</i> .

35

ADDITIONAL COPIES
OF THIS PUBLICATION MAY BE PROCURED FROM
THE SUPERINTENDENT OF DOCUMENTS
GOVERNMENT PRINTING OFFICE
WASHINGTON, D. C.
AT
10 CENTS PER COPY









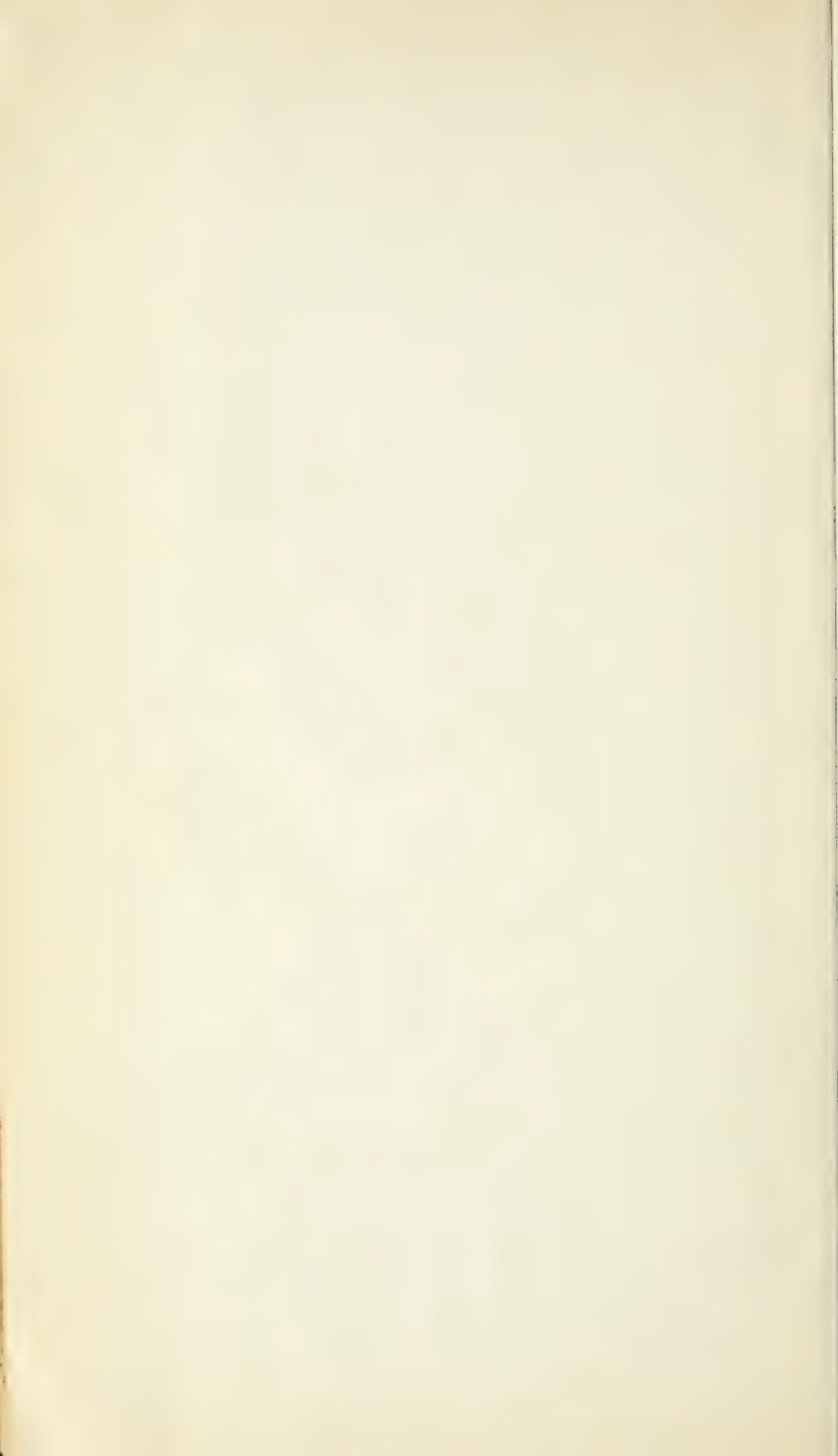



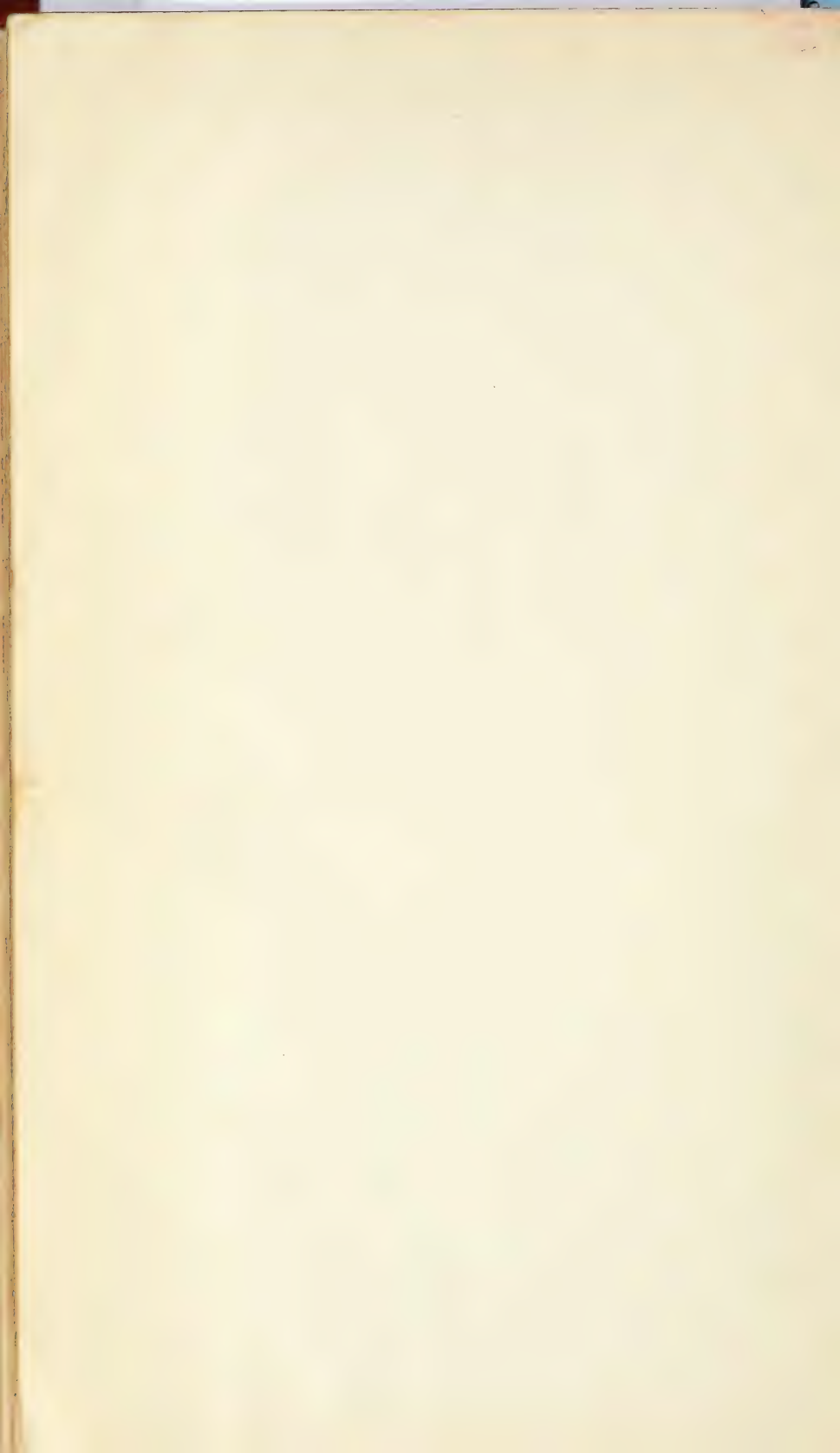

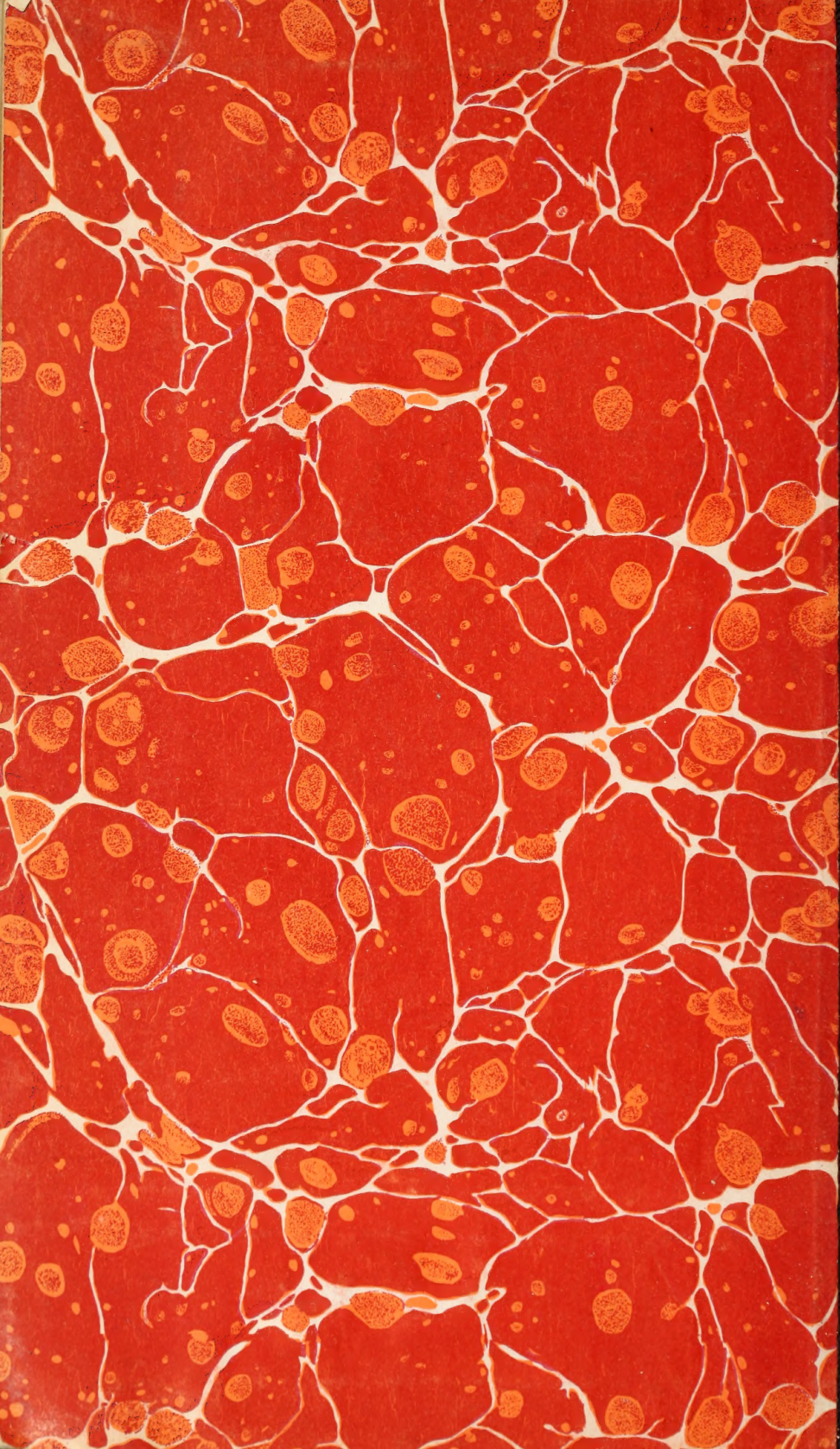



LIBRARY

BUREAU OF

AGRICULTURAL ECONOMICS

— 0 —

U. S. DEPARTMENT OF AGRICULTURE

* NATIONAL AGRICULTURAL LIBRARY



1022563521